

Considerations for Pelleting for Aquaculture

BY EUGENIO BORTONE, PH.D, PAS, DPL. ACAS

REVIEWED AND EDITED BY CHARLES STARK, ADAM FAHRENHOLZ, AND CASSANDRA JONES

Global production of aquafeed is approximately 6.3 million metric tonnes (MMT) per year (FAO, 2012). Of this total, approximately 44 MMT is inland production and 19 MMT is marine production. The growth in aquaculture will continue as countries increase aquaculture production to meet the demand for food production, specifically as a protein source.

The aquafeed mill

Feed mills designed to produce aquafeed have major differences when compared to traditional animal feed mills. To understand the differences, it is necessary to have a basic understanding of an aquafeed plant layout. **Figures 18-1, 18-2 and 18-3** show the three major operational or cost centers of a plant designed to produce shrimp or fin fish feeds.

One of the major differences between traditional and aquafeed feed mills is in particle size reduction. As illustrated in **Figure 18-1**, aquafeed feed mills depend more on the post-grind system rather than the pre-grind system used to produce most other animal feeds. In pre-grind systems the major ingredients are ground prior to being weighed. In aquatic feed mills, the ingredients are weighed prior to being ground (see **Figure 18-2**). The pre-weighed meal is also subjected to a pre-mixing step as it passes through a hopper with internal flights creating a cascade mixing action.

Figure 18-1. Proportioning, dosing and weighing system cost center. Drawing courtesy of Rosal Agro Instalaciones.

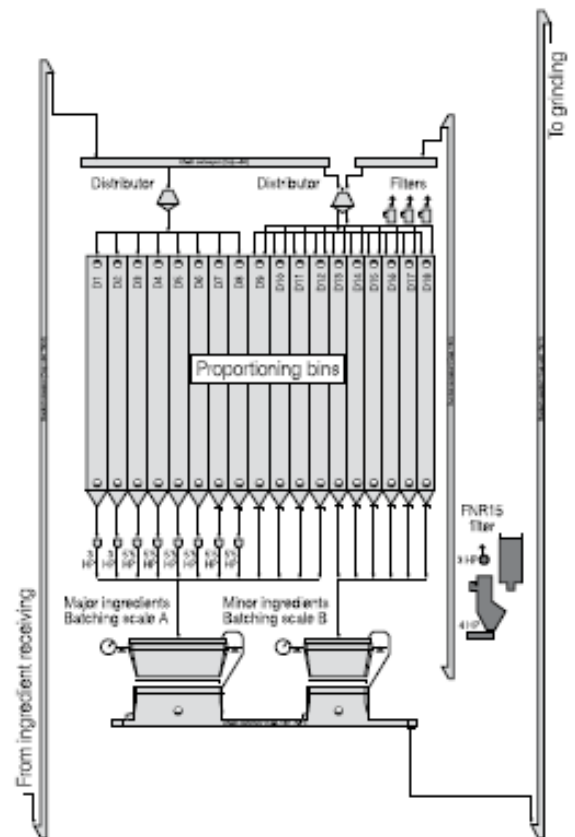
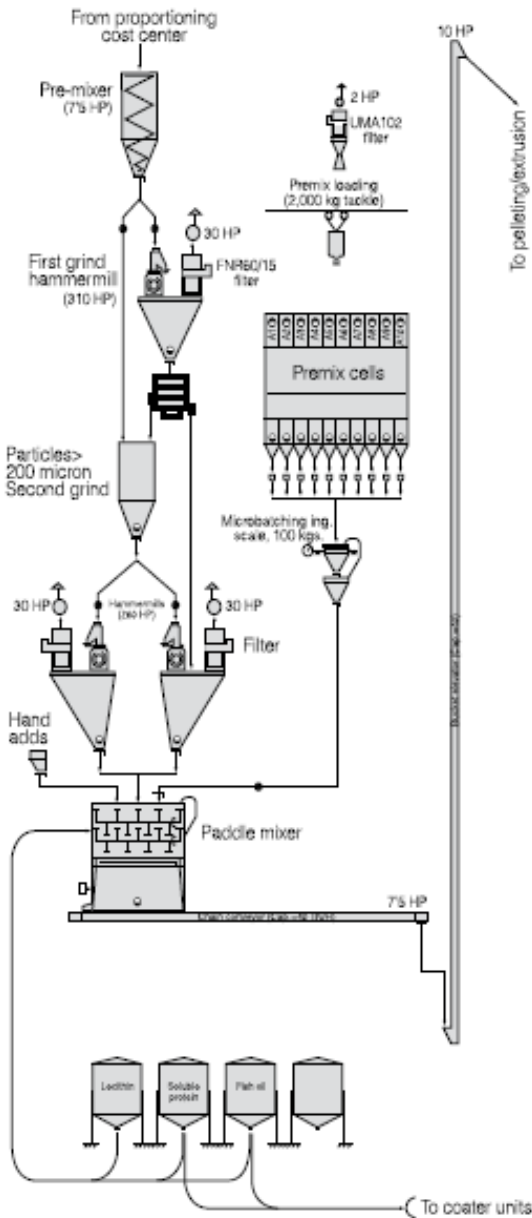

Figure 18-2. Grinding and mixing cost centers. Drawing courtesy of Rosal Argo Instalaciones.



Post-grinding process

A post-grinding system is necessary in aquatic feeds because of the inclusion of difficult-to-grind ingredients such as fishmeal. It allows the production of a more uniform particle size. Another advantage of the post-grinding system is that it does not require storage for the individual ground ingredients, and does not require a grinding process for each ingredient.

Hammermills have long been used for particle size reduction in the animal feed industry. A typical

hammermill for aquaculture feed applications will have a motor rotational speed of 3,600 RPM, twice as high as the speed used in most livestock and poultry feeds.

Figure 18-3. Pelleting and extrusion cost centers. Drawing courtesy of Rosal Argo Instalaciones.

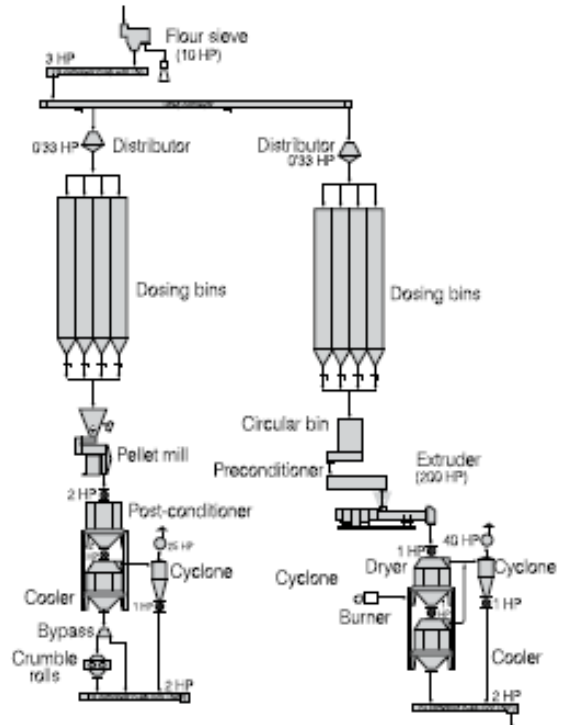

For larval shrimp feeds it is necessary to reduce the particle size of an ingredient or blend of ingredients to as small as 100-150 microns, with a maximum of 5% retained on an 80-mesh Tyler screen. For adequate feed conversion in growing shrimp it is generally recommended that the average mean geometric particle size be 250 microns, with a maximum of 5% retained in a 60-mesh Tyler screen.

Uniform particle size will also improve the moisture and heat transfer during preconditioning of the feed prior to pelleting. With a uniform particle size the moisture distribution from steam condensation will occur more evenly. If the particles are not uniform, then the smaller ones, with a larger surface area, will absorb more moisture and could tend to produce “spotted” pellets that can have poor water stability.

Another major difference between traditional and aquatic feed production can be found in the pelleting operation. Pellet mills in traditional feed mills use shorter residence time (10-60 seconds) preconditioners as compared to shrimp feeds that require preconditioning times of three or more minutes. The compression ratio used in the pellet dies is also different. Shrimp feeds require compression ratios of 20-24 (diameter of the bore divided by the effective travel length), while poultry and swine feeds require compression ratios of 10-12. A higher compression of shrimp feeds is required in order to produce highly water-stable feeds. With increased compression, the production capacity is reduced. Therefore, a pellet mill set up to produce 30 MT/hr of poultry feed may only produce 4-5 MT/hr of high-quality shrimp feed.

Formulation

The high protein levels of most aquafeeds are achieved by using ingredients high in protein such as fishmeal, shrimp head meal, squid meal, clam meal and soybean meal. Soybean meal use has increased considerably in an attempt to reduce feed costs and lessen the demand on fishmeal. Many of these high protein ingredients also have a high oil content. When these ingredients are ground, their high oil content can clog fine mesh screens. To avoid this, it is recommended that ingredients high in oil be ground together with low oil content ingredient(s) such as cereal grains.

For shrimp feed manufacturing, the most common low oil ingredients used in combination with protein meals high in oil are whole wheat grain, wheat flour, wheat gluten, and defatted soybean meal. Because fibrous ingredients do not grind well, wheat middlings and similar ingredients are not used in shrimp formulations. Although the fiber particles can be reduced in size to a point, because they are flexible they can be pulled through the screen holes by the air-assist system without being reduced to the target particle size. These large fiber pieces will act as avenues for water penetration, and upon soaking, will expand, leading to the creation of voids resulting in loss of pellet integrity. For aquafeed manufacturing it is recommended that high-fiber ingredients not exceed 3% of the total

formula.

Formulation can perhaps be better understood when we consider feeding a 1 g shrimp. For this stage of physiological development the shrimp will consume approximately 12% of its body weight per day, or approximately 0.12 g of feed. Every pellet or crumble of feed should contain all the nutrients for which the diet has been formulated. In the event the ingredients are not mixed properly, reduced growth rates, high morbidity and mortality, and poor feed conversion could result.

Once the major ingredients are ground to the target particle size, they are passed to the mixer where other minor ingredients such as heat-labile vitamins and some of the liquids are added. From the mixer, the mixed formula meal is sent to the pelleting line (**Figure 18-3**).

Mixing: Sequence of ingredient addition

The order in which ingredients are added to the mixer can affect the mixing efficiency. The sequence of addition will depend on the formulation, type of ingredients, and the activation of natural or synthetic binders. Particular attention should be paid to the addition of binders to the mix. In most cases, binding agents need to be activated by water and by temperature. However, if a hydrophobic liquid, such as oil (i.e., fish oil), is added in the mixer and coats the synthetic or natural binder, it will not be able to readily absorb water and start development of its binding properties, which can reduce the water stability of the pelleted feed.

Aquaculture feed ingredients are added to the mixer in the following order:

- All major ingredients in order from greatest to least (fishmeal, soybean meal, cereal flours, etc.). Allow some mixing time (1-2 minutes depending on type of mixer) prior to adding the minor ingredients (trace elements, vitamin pre-mixes, etc.), which will also be added from greatest to least.

- Once all the dry ingredients are added, they should be mixed for a predetermined time before the addition of liquid ingredients.
- To prevent clump formation, the liquid ingredients must be sprayed onto the mixed feed as uniformly as possible, with water being the first liquid added because water must be internalized into the particles, improving the binding capacity once subjected to higher temperatures in the pelleting or extrusion processes.
- After the water is added, other aqueous ingredients should follow.
- Lipids should be added last to prevent coating the particles and inhibiting the hydration of the starch and other binding agents that may be present in the formula.
- After all liquid ingredients are added, mix for a predetermined time to ensure adequate dispersion.

Production basics for aquafeed

The most common mixer used in commercial aquaculture feed manufacturing today is the horizontal (**Figure 18-4**) mixers.

Figure 18-4. Horizontal mixer.

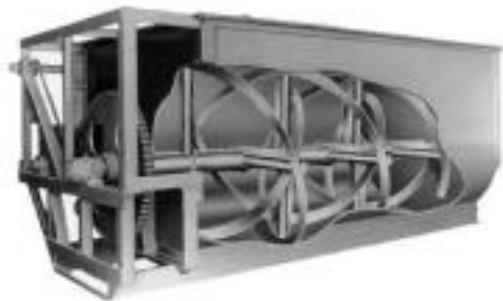

Because of short mixing cycles that permit up to 20 batches per hour, most new shrimp feed mills are using horizontal drop-bottom mixers.

Shrimp feed has bulk densities between 550-650 g/l and is a sinking feed. The most common and most cost-effective method to produce high-density, water-stable shrimp feed is the pelleting process.

After being mixed, the shrimp feed is transferred to the pelleting supply bin. A variable speed feeder transfers it to the preconditioner where steam is added to increase temperature and moisture levels. Preconditioning is the third most critical step in the process for the production of highly water-stable shrimp feeds, as the steam activates natural or synthetic binders to achieve high water stability.

The shrimp feed industry in North, Central and South America has relied more on the short-term, single-pass conditioner in contrast to Asia, where long residence time conditioners are commonly used. This is because the aquafeed industry was developed out of feed mills designed to manufacture broiler and swine feeds. However, with the growth of the aquaculture industry, more and more feed mills are making the necessary changes to produce high-quality shrimp feed.

Single-pass conditioners study

A single-pass conditioner is shown in **Figure 18-5**. A test run was conducted (Bortone, 1995) in this conditioner with a 35% CP shrimp diet. It was run to compare the effects of using low-pressure steam (1 kg/cm^2) and high-pressure steam (2 kg/cm^2). The pellet mill used in this trial was a CPM Century 125 HP pellet mill with a die orifice diameter of 2.4 mm and compression ratio of 20.8 (2.4 mm x 50 mm standard no relief). In this trial, the effect of post-pellet conditioning was also evaluated.

Figure 18-5. Single-pass conditioner. Photo courtesy of Sprout-Matador.



The post-pellet conditioning was accomplished by placing hot pellets coming out of the die into a styrofoam container for five minutes. Water stability (WS) of pellets not subjected to post conditioning (OC) versus post conditioned (PC) was

measured as percent dry matter left after four hours of water immersion. For this method, 80% WS is considered good and beyond 90% is considered excellent.

Results indicated that, at a pressure of 2 kg/cm², conditioned mash temperature and pellet temperature exiting the die were higher (95 vs. 92°C and 98 vs. 95°C) than at 1 kg/cm² pressure. In contrast, water stability (WS) was higher for low-pressure (LP) pellets (75.2 vs. 68.0%). The higher pellet temperature of high-pressure (HP) pellets is due to lower moisture content, which in turn had higher friction as they exited the die. This higher temperature of HP pellets is also responsible for the higher post conditioning temperatures achieved (95.0 vs. 94.0°C).

Water stability for PC pellets was substantially higher than for pellets cooled right after exiting the die at the same pressure. However, there was no difference in water stability for PC pellets at either of the pressures tested (92.8 vs. 92.2). The results clearly show an advantage in using post conditioning and this should be considered, especially in situations where double-pass conditioners are not available.

A better alternative to the single-pass short retention time conditioner is the double-pass (**Figure 18-6**), and even triple-pass conditioner. Stacking conditioners on top of each other reduces the total length of the unit. Many poultry and swine operations are turning their attention to double-pass conditioners as a way to increase pellet durability, reduce fines, increase pellet digestibility and as a means for sanitizing the feed.

A disadvantage of multiple-pass conditioners is the possibility of reduced mixing when the speed is reduced or the paddle configuration is changed in an attempt to increase dwell time. This dilemma can be overcome by using double agitators that rotate at different speeds, maintaining adequate mixing and dwell times. This is known as the double-differential conditioner (**Figure 18-7**).

Figure 18-6. Double-pass conditioner. Photo courtesy of Sprout-Matador.



Figure 18-7. Double-differential conditioner. Photo courtesy of Wenger, Inc.



A comparison between (Bortone, 1996) a Sprout-Matador double-pass conditioner (DPC) and a CPM single-pass (SPC) conditioner was made to determine the effects of long (two minutes) vs. short retention time (30 seconds) on shrimp feed water stability. In this case, die specifications (2.4 mm x 50 mm working area, high-chrome die and closed-end corrugated roller shells), formula (35% CP high-wheat flour) and processing conditions were equal. The pellet mills were the same brand of equipment and were run at the same die speed side by side. The steam was injected at 1.5 kg/cm² of pressure. In this trial, post-pellet conditioning (PPC) of five minutes was tested for both DPC and SPC.

Results indicated that a DPC achieved higher mash conditioning temperatures than the SPC (97.5 vs. 82.4°C). Also, mash moisture was higher for DPC than SPC (15.7 vs. 12.9%). These results corroborated the advantage of dwell time on mash temperature and moisture. This experiment demonstrates that as the residence time increases,

there is more time for steam to condense and transfer its energy to the product. The improvement on mash conditioning also resulted in better water stability for DPC than for SPC (73.0 vs. 62.6); however, higher water stability results were obtained by post conditioning the hot pellets (92.6 vs. 79.5%).

Die thickness and compression

Most shrimp dies are manufactured with stainless steel, with a high chrome content to prevent corrosion, as most shrimp formulas can contain acidic materials, and to reduce the coefficient of friction. Where high lipid diets are used, and increasing the coefficient of friction is required, the dies should be manufactured of carburized stainless steel.

For shrimp feed manufacturing it is common to use a die with an effective thickness of 40 mm when using 2.0 mm orifices and a compression ratio of 20. For formulas high in starch and die compression ratios of 18 or more, it is recommended to lubricate the formula by adding 1-2% oil (fish oil) in the mixer. This addition needs to be accounted for and subtracted from the total applied during coating.

Typically shrimp feed dies have no counterbores (standard die). The main reason is to maintain pellet quality (length, hardness, compression ratio, water stability) as consistently as possible. Shrimp pellets produced with a die having the outside rows relieved will have different dwell times in the effective pelleting zones, causing pellets to be less compacted, softer and possibly less water-stable than pellets produced with the standard die.

Shrimp feed dies should have optimum hole patterns to maximize open area and throughput. As the size of the die orifice diameter decreases, the pelleting capacity also decreases. This is because the perforated area (total open area) is considerably smaller in dies with small diameter orifices than in large diameter ones (i.e., 2.0 mm vs. 6 mm). This explains why pellet mills with throughputs of 20 MT/hr for poultry and swine diets with dies of 6

mm can only produce 3-5 MT/hr of shrimp feeds (2.3 mm diameter).

Also, the compression ratio used for poultry and swine diets is much less than that used to produce good quality shrimp feeds (12-14 vs. 18-20, respectively). Therefore, when comparing dies from different manufacturers, use this as one of the selection criteria, the total open area and not just the price, and always request dies with the most open area to increase capacity.

The function of the rollers is to force the material into the die. Roller adjustment is critical in the pelleting process of shrimp feed. It is recommended to adjust the rollers as close as possible to the die face. The gap of the roller and the die face should be approximately 0.5 mm. The rollers should be adjusted at least every two shifts using the touch skip method. In shrimp feed it is common to have the rollers over-adjusted with the expectation that this would increase throughput, when in reality, the opposite will occur. Very tight rollers will cause spalling of the die (Figure 18-8).

Figure 18-8. Spalling of the die face caused by overly tight rollers.

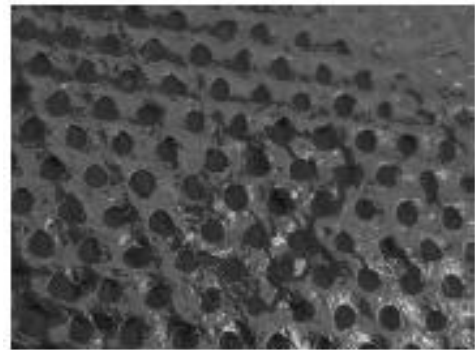

Roller shells are made with different configurations—dimpled, corrugated open ends and corrugated closed ends. It is important to use the rollers that have the highest traction possible to push the moist mash through the die. In most cases, the preferred roller shell is the corrugated closed ends (see Figure 18-9) since this offers higher traction. The closed channels prevent the mash from flowing sideways, thus pushing more towards the die face where it is pushed out through holes.

Figure 18-9. Corrugated shells closed ends. Photo courtesy of Jacobson Inc.

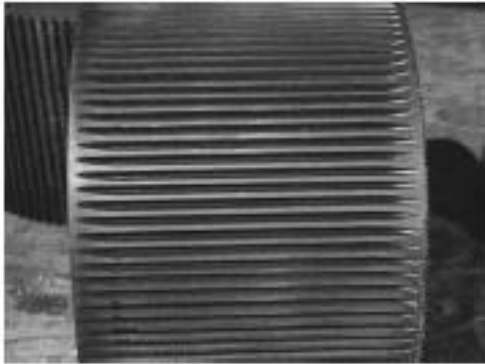

The shells should be rotated at least twice during the life of the die. It is also important to have each die placed with its matching set of roller shells. This is because the shells will conform to the wear of the die, and if used with a different die, will not have the same wear pattern, thus affecting throughput and possibly damaging the die.

The shells can be fine groove (**Figure 18-10**) or standard (**Figure 18-11**) groove configuration. For moist meals, as in the case of shrimp feed, the fine groove is the more desired one because it has good traction due to greater surface area of contact and it also provides a quieter run.

Figure 18-10. Fine groove shell.

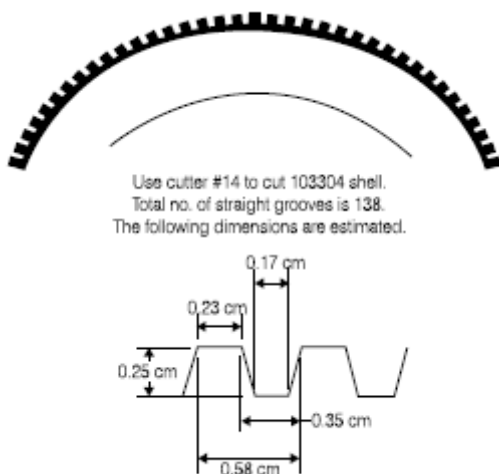
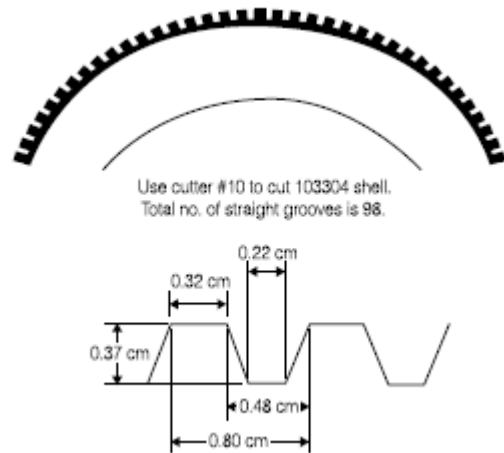

Figure 18-11. Standard groove shell.



Pellets are cut as they exit the die. The knives used to cut the pellets need to be as sharp as possible. Dull blades will only knock off the pellets, creating stress cracks that will cause the pellets to break into smaller pieces with fines production. The stress cracks also provide an avenue for water penetration, which can result in poor water stability. As a general rule, all blades need to be replaced at least every other shift.

Post-pellet cooking

Why is water stability so improved with post conditioning? As discussed previously, pellets subjected to some form of post conditioning had improved water stability. In those trials, post conditioning was accomplished by just keeping the pellets at their own temperature for a determined period of time. The increments in time in which the pellets are kept warm have two positive effects. First, the pellets are not subjected to the sudden change in temperature due to the cold draft of the cooler that causes the pellets to contract rapidly. The sudden contraction causes microscopic cracks that are avenues for water penetration and result in poor water stability. Post conditioning, as a very slow cooling process, allows for the contraction to occur very slowly and permits particles to come together in a tight structure rather than the sudden cooling process, which leaves these particles separated (no maturation) with micro-cracks or voids. Second, post conditioning provides the means for further cooking the starches, which in turn improves water stability. After all, the degree

of starch gelatinization is a time- and temperature-dependent process.

Post-pellet cookers offer an alternative to substantially improve shrimp feed water stability. There is no published literature that shows a scientific explanation as to why post conditioned pellets have better water stability than pellets not subjected to this treatment. However, research (Bortone, 1995) with shrimp feeds using regular pelleting, extrusion and expander and pelleting technologies follow the same trend. No matter what process is used, water stability is 10-20% better when the pellets are subjected to a post cooking time.

As pellets exit the die some expansion is exhibited, but if allowed to cook slowly, the pellets' diameter starts to shrink. This shrinkage brings the particles together, including starch granules, protein and even other binding agents present in the formula. In contrast, when pellets are subjected to an abrupt change in temperature, as in the case of the pellets immediately reaching the cooler, they do not have time to shrink in size, and micro-cracks develop.

Post conditioners, or post-pellet cookers, are not new in the Eastern hemisphere. These units of operation have slowly made their way to the Western hemisphere in the last five years, where they have been recognized to improve pellet water stability.

A few years ago, this unit was regarded as a “trade secret,” but not so long ago feed manufacturers learned about it and started implementing its use. The main post-pellet conditioners used in the shrimp feed industry in Asia were horizontal units. These horizontal units were designed to retain the pelleted feed for up to 20 minutes. The units can be anything from slowly-moving drag conveyors to large holding bins.

Horizontal post conditioners

These units may be considered a simple “box.” But there is more to post conditioners. The units are designed to either further heat the pellets via live

steam addition or keep them as hot as possible (jacketed). Some units incorporate steam injection, temperature control zones and PLC controls to monitor temperature and humidity.

To understand the size of a horizontal unit we also need to take into account the maximum capacity of the pellet mill. This is the highest capacity at which the “best quality” feed is made. Therefore, if the pellet mill is known to produce pellets of high quality at 3 MT/hr, with 10 minute residence time in the post conditioner, then these parameters should be used as a guideline to size the unit.

Figure 18-12 shows post conditioning time optimization trials using styrofoam boxes to simulate a post cooker unit. The boxes are labeled 5, 10, 15 and 20 minutes (**Figure 18-13**) and the pellets were collected at a known capacity. This is repeated at various pellet mill capacities to determine the optimal capacity without reducing pellet water stability.

Figure 18-12. Styrofoam box simulating a post conditioning chamber.



Once the minimum residence time is estimated, one can proceed to size the unit or use this information to request the minimum residence time required from the equipment vendor.

Figure 18-13. Styrofoam boxes labeled 5, 10, 15 and 20 minutes to measure the effect of post cooking time at 4 MT/hr.



Calculate the space needed

How big does this unit need to be to hold the product for 10 minutes? To determine the dimensions of the bed needed to hold the product for the required time, use the following equation:

$$\text{Footprint area (FPA)} = (\text{rate} \times \text{time}/60) / (\text{depth} \times)$$

For example:

$$\text{Production rate} = 3,000 \text{ kg}$$

$$\text{Feed density} = 650 \text{ kg/m}^3$$

$$\text{Desired bed depth of pellets} = 0.3 \text{ meters}$$

$$\text{Post conditioning time} = \text{minimum } 10 \text{ minutes}$$

$$\text{FPA} = (3000 \text{ kg} \times (10 \text{ minutes}/60 \text{ minutes})) / (0.3 \text{ m} \times 650 \text{ kg/m}^3) = 2.56 \text{ m}^2$$

The total footprint for the bed can be a combination of lengths and widths as shown on **Table 18-1**.

Table 18-1. Settings for a 10 minute residence time in a horizontal post conditioner.		
Length, m	Width, m	Area, m ²
2.56	1.00	2.56
2.84	0.9	2.56
3.20	0.8	2.56
3.66	0.7	2.56
4.27	0.6	2.56
5.12	0.5	2.56

The dimensions of the horizontal post conditioner depend on the floor space available. The dimensions can change considerably if the residence time is doubled. This will practically require double the space of the footprint or a change of bed depth. One critical aspect to consider is the bed width of the unit. The wider the bed, the shorter it will be. If it is too wide, it will require an oscillating arm feeder to evenly distribute the pelleted feed across the bed width. This adds an extra cost to the unit. Other important aspects to consider are: Steam injection; jacketed sections to maintain the temperature product; temperature control thermocouples (closed-loop control); and total moisture coming out of the post conditioner. The latter is often overlooked and may result in serious problems if live steam is injected. This can result in high moisture in the finished product because a cooler alone will not be able to remove the excess.

Horizontal post conditioners can work well where floor space is available, but when sizing a unit or designing a new line, consider other important aspects such as maintenance. Horizontal units require more maintenance due to the large amount of moving parts used. Also, they require more cleaning to avoid cross-contamination or mold. One of the major advantages of these units is the fact that the pelleted feeds are gently handled, so fewer fines are produced.

Vertical post-pellet conditioners

The vertical post-pellet cooker (**Figure 18-14**) includes the option of further increasing the degree of cooking by adding steam to the unit, and a steam jacket to control the temperature of the unit. The addition of steam, coupled with a long residence time of up to 20 minutes, increases the total moisture content from 17% (out of the die) to 22%. Since starch gelatinization is a temperature-, moisture- and time-dependant process, it is without a doubt that such a system can further improve the water stability of the pellets. At these high moisture contents, however, the system also requires a dryer to reduce the excess moisture that cannot be achieved by evaporative cooling alone.

These can be simple round holding bins or more sophisticated square units. The main problem with improperly-designed vertical post conditioners is that the product can bridge inside the bin. This results in blockage of the whole process and downtime to break up the lumped product.

Figure 18-14. Vertical post conditioner. Photo courtesy of Geelen.



Most modern vertical post conditioners avoid hang-ups by providing sliding gates that are adjusted according to the pellet diameter. These sliding gates are designed to gently lift the bed, causing the product that may have formed a block to gently break and flow out.

Compared to the horizontal unit in the previous footprint area (FPA) example, a vertical unit will only require floor space of 0.52 m² (product depth was calculated at 1.5 m)—which is a 237% smaller footprint area. The disadvantage of this unit is that it requires more head space. If height is not an issue and footprint is, then the vertical unit has more advantages than the horizontal unit.

In areas of high relative humidity and temperature it is easier to achieve the desired moisture and temperature in the preconditioner without adding steam to the pellets in the post conditioner. But if steam is added to the post conditioner, conditions

may exist to produce high-moisture pellets that will mold. If this is the case, you may need a dryer and a cooler to reduce the total moisture of the pellets to 9-10% and the temperature to no more than 5° above ambient.

Pellet crumbling and screening

In the crumbling process, whole pellets are cracked to produce starter diets, which are used to feed shrimp in their early developmental stages. The whole pellets used in the production of starter diets must meet the same standards for water stability and pellet durability. It should not be assumed that because the pellets will be cracked, the pelleting process could be altered with the sole objective of increasing capacity. Therefore, pellets produced for the crumbling process should be subjected to the same processing conditions necessary to achieve the highest possible quality standards.

The equipment used to crush pellets into small particles is known as the crumbler (Figure 18-15) and consists of a set of two rolls that run at different speeds, each with a different set of grooves (Figure 18-16). The crumbler is usually located after the dryer/cooler. Shrimp starter crumbles can typically be as small as 0.5 mm and as large as 3.0 mm. With whole pellets that are 2.2 mm in diameter and 6-8 mm long, the crumble distribution typically is 60, 30 and 10% for sizes in the ranges of 1.5-2.5, 1.0-1.5 mm and 0.5-1.0 mm, respectively. The grooves and roller spacing determine the crumble sizes.

Figure 18-15. Crumble roller assembly.

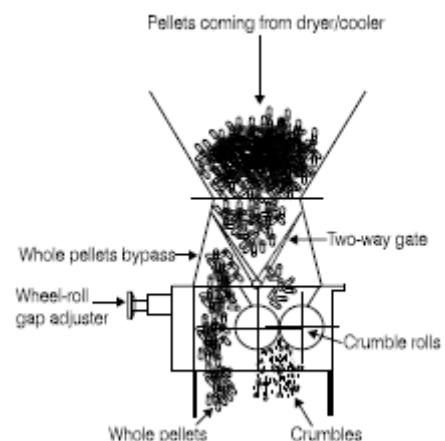
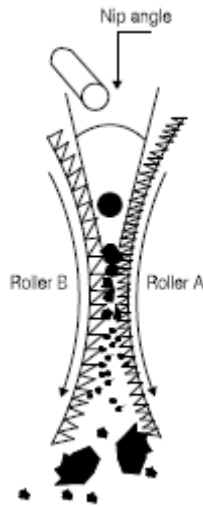

Figure 18-16. Crumble rollers rotate at different speeds and have different corrugations.



An important objective of crumbling is to reduce the amount of fines that are produced as the pellets are crushed. More fines are generated when the pellet diameter is too large in relation to the particles that need to be produced. Larger diameter pellets cannot properly enter through the nip angle of the rollers, causing more fines as the rollers erode them. The average amount of fines produced is 15%. These fines need to be removed, and, unlike what is done with other farm animal feeds, they should be sent to an ingredient bin and not to the pellet mill. Fines that are returned to the pellet mill can drastically reduce pellet quality. Some pellets pass through the crumble rolls without breaking. These pellets must be separated downstream and redirected to the crumbler.

The screening process removes clumps produced in the pelleting process. These clumps or larger pieces are removed by the sifter as overs, and should be separated and re-ground. When pelleting is adequate, no more than 5% fines should be produced. Exceeding this number may indicate problems in the pelleting process or mechanical handling that is too harsh.

The crumbling process produces different particle sizes that need to be segregated into the different fractions with a screener. The most common equipment used in the separation of crumbles of various sizes is the horizontal rotational screener

(**Figure 18-17**). These screeners are composed of multiple stacked decks of sifting screens. These units rotate and vibrate in three planes, making them more efficient than common screener separators. The rotational action is controlled by a set of weights and a motor placed at the bottom of the unit. Shifting the weights can increase or decrease the dwell time by changing the direction of flow on the screen.

Figure 18-17. Horizontal rotational screener used to segregate crumbles.



Coating

Coaters are necessary to add those liquids that were not included in the mix to avoid affecting the processing and overall quality of the feed. One of the most common ingredients added post-pelleting or post extrusion is fish oil.

The most common method for adding fish oil is through a drum coater (**Figure 18-18**). Drum coaters are equipped with spray nozzles that apply the liquid as the feed is gently tumbled. In the last ten years, new coating systems have entered in the aquatic feed market. One such piece of equipment is the vacuum coater (**Figure 18-19**). This is basically a batch unit that is filled with the pelleted feed and then subjected to vacuum or 200 mbar of absolute pressure. This allows for liquids to be drawn into the pellet by capillary forces. Once the liquid is applied and subjected to vacuum, the pressure must be equalized back to atmospheric pressure.

Figure 18-18. Drum coater.



One of the advantages of this type of coater is the precision for liquid applications, as well as the degree of liquid distribution through the feed. However, this type of coater works best for particles that have some porosity such as floating extruded feeds, which permits the liquid to move inward under a vacuum. For pelleted feeds where the surface is rather smooth, the use of vacuum coaters is still questionable.

Figure 18-19. Vacuum coater. Photo courtesy of Forberg International Ltd AS.

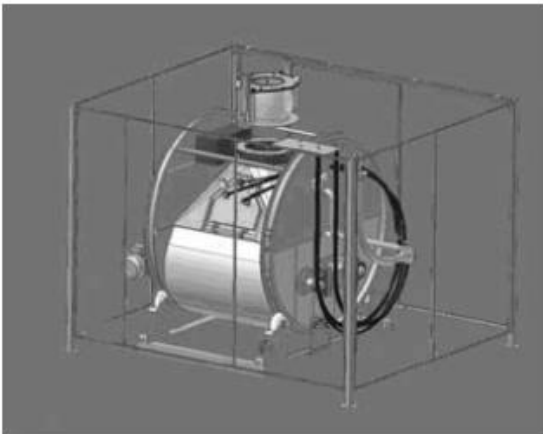

Another coater unit used in shrimp feeds is the mist coater (**Figure 18-20**). This type of coater offers the advantage that it is a continuous unit and uses less space than the drum coater. In the case of mist coaters, the liquid is not sprayed but rather applied as a curtain or mist produced by centrifugal force imparted by rotating plates (**Figure 18-21**). As the feed enters, it is exposed to the mist of the liquid

ingredient. The fine particles of liquid then coat the pellets, which are deposited in a mixing conveyor.

Figure 18-20. Mist coater unit. Photo courtesy of APEC Inc.



The key element in any vacuum coating system is the precision at which the oil or fat is added to the product. This step is key to maintain a good balance of total energy to protein. If too much fat is added, the nutritional value of the feed can be adversely affected, impairing growth and performance of the target aquatic species.

Figure 18-21. Discs of mist coater. Photo courtesy of APEC Inc.



Dr. Eugenio Bortone is a Sr. Principal Scientist for PepsiCo-Frito Lay. He previously served as the R&D Manager for Ralston Purina and earned his B.S., M.S., and Ph.D. from Kansas State University.

This content was edited and reviewed by Dr. Charles Stark, Jim and Carol Brown Associate Professor of Feed Technology at Kansas State University, Dr. Adam Fahrenholz, Assistant Professor of Feed Milling at North Carolina State University, and Dr. Cassandra Jones, Assistant Professor of Feed Technology at Kansas State University.